

# Goalrilla™

**The Toughest  
Basketball System  
on the Planet.**

MODEL NO.

**B6101**

**&**

**B6101W-1**

**DC72E1**

**BASKETBALL SYSTEM**

## **OWNER'S MANUAL**

1. **Read this manual carefully before starting assembly.** Read each step completely before beginning each step.
2. **Some smaller parts may be shipped inside larger parts. Check inside all parts and cartons before assembling or ordering parts.**
3. **To make assembly of your basketball system easier, use the Hardware Identifier on page 3 and 4 to identify and sort all fasteners. Check all cartons for kits. All hardware is not located in one kit.**
4. **Do not tighten hardware until instructed to do so.** If hardware is tightened too soon, mounting holes may not align and parts may not easily fit together. Leave locknuts slightly loose until you are instructed to tighten them.
5. An electric screwdriver is helpful in assembly. However, please **set at low torque and use caution** because you could overtighten the hardware and strip the screws.
6. **Save this instruction and your proof of purchase (receipt) in the event that the manufacturer has to be contacted for replacement parts.**

**Please Do Not Return This Product To The Store!**

Contact MICCA Group customer service department at:

Phone: 1800-551-443 Toll Free!

E-mail: [information@goalrilla.com.au](mailto:information@goalrilla.com.au)



Please visit our World Wide Web site at: [www.Goalrilla.com.au](http://www.Goalrilla.com.au)

ON-LINE TROUBLE SHOOTING

TECHNICAL ASSISTANCE

ON-LINE PARTS REQUESTS

FREQUENTLY ASKED QUESTIONS

ADDITIONAL MICCA Group PRODUCT INFORMATION

2L-7235-04

**ESCALADE®**  
**S P O R T S**

Escalade® Sports products may be manufactured and/or licensed under the following patents.  
6419596, 6179733, 5919102, 5071120, 4798381, 4424968, D326128, 8398509

Additional patents may be pending. One or more of the listed patents and/or pending patents may cover specific product.

©2022 Escalade® Sports



# SAFETY INSTRUCTIONS



**FAILURE TO FOLLOW THESE WARNINGS MAY RESULT IN SERIOUS INJURY AND/OR PROPERTY DAMAGE.**

**Owner must ensure that all players know and follow these rules for safe operation of the system.**



## WARNING

**FAILURE TO FOLLOW THESE WARNINGS MAY RESULT IN SERIOUS INJURY AND/OR PROPERTY DAMAGE.**

**Owner must ensure that all players know and follow these rules for safe operation of the system.**

- Only hang from the rim briefly to regain balance or avoid injuring others. Release the rim as soon as safely possible.
- During play, especially when performing dunk type activities, keep player's face away from the backboard, rim, and net. Serious injury could occur if teeth/face come in contact with backboard, rim, or net.
- Do not slide, climb, or play on pole.
- When adjusting height, keep hands and fingers away from moving parts.
- Do not allow children to adjust system.
- During play, do not wear jewelry (rings, watches, necklaces, etc.) Objects may entangle in net.
- Keep water and organic material away from pole. Pole can rust and fail.
- Once a month check pole and all metal parts for rust. Completely remove rust and repaint with exterior enamel. If rust has penetrated any steel part, replace that part immediately.
- Check system before each use for loose hardware, signs of rust and instability. Repair before each use. Never play on damaged equipment.
- Wear a mouthguard when playing to avoid dental injuries.



## SAFETY INSTRUCTIONS



**FAILURE TO FOLLOW THESE SAFETY INSTRUCTIONS MAY RESULT IN SERIOUS INJURY, PROPERTY DAMAGE AND WILL VOID WARRANTY.**

**Owner must ensure that all players know and follow these rules for safe operation of the system.**

**To ensure safety, do not attempt to assemble this system without following the instructions carefully. Proper and complete assembly, use and supervision is essential for proper operation and to reduce the risk of accident or injury. A high probability of serious injury exists if this system is not installed, maintained, and operated properly.**

- If using a ladder during assembly, use extreme caution.
- 4 people are recommended for this operation.
- Seat the pole sections properly (if applicable). Failure to do so could allow the pole sections to separate during play.
- Before digging contact utility company to locate underground power cables, gas and water lines. Ensure there are no overhead power lines within 20 ft. (7m) radius of pole location.
- Climate, corrosion or misuse could result in system failure.
- If technical assistance is required, contact the manufacturer.
- Minimum operational height is 6'6" (1.98m) to the bottom of backboard.

*Most injuries are caused by misuse and/or not following instructions.  
Use caution when using this system.*

## WARNING!

**Failure to observe this warning may cause property damage and/or serious injury.**

(Affixed to backboard)

Only hang from the rim briefly to regain balance or avoid injuring others. Release the rim as soon as safely possible.  
Rim height adjustments should be made under parental supervision.  
Wear a mouth guard when playing to avoid dental injuries.  
During play, do not wear jewelry (rings, watches, necklaces, etc).  
Objects may entangle in net.

# HARDWARE IDENTIFIER

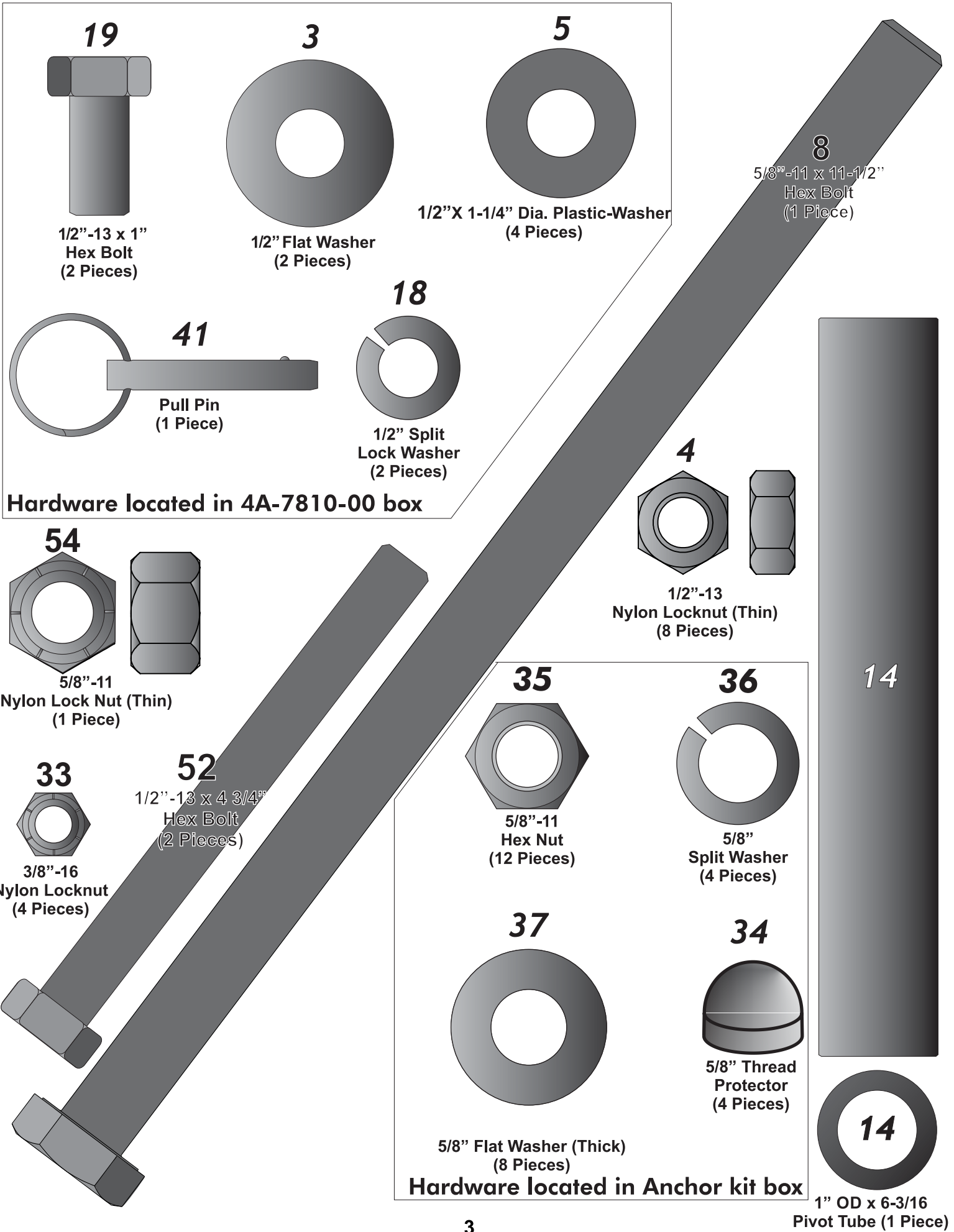

**19**

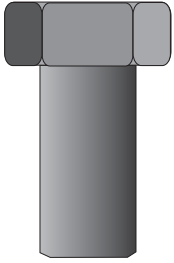

1/2\"-13 x 1\"  
Hex Bolt  
(2 Pieces)

**3**

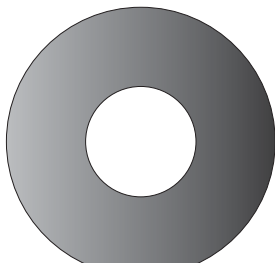

1/2\" Flat Washer  
(2 Pieces)

**5**

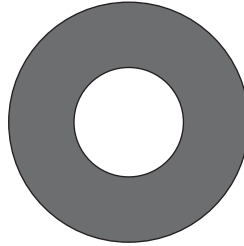

1/2\"X 1-1/4\" Dia. Plastic-Washer  
(4 Pieces)

**8**

5/8\"-11 x 11-1/2\"  
Hex Bolt  
(1 Piece)

**18**

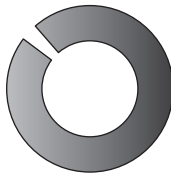

1/2\" Split  
Lock Washer  
(2 Pieces)

**41**

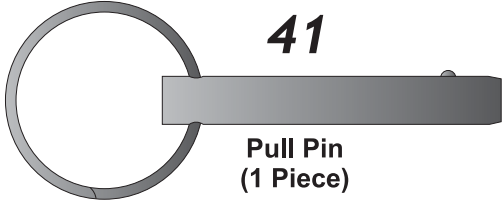

Pull Pin  
(1 Piece)

## Hardware located in 4A-7810-00 box

**54**

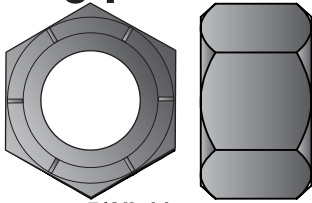

5/8\"-11  
Nylon Lock Nut (Thin)  
(1 Piece)

**4**

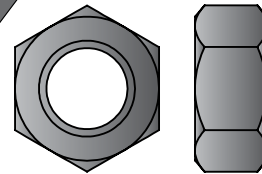

1/2\"-13  
Nylon Locknut (Thin)  
(8 Pieces)

**33**

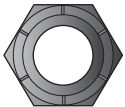

3/8\"-16  
Nylon Locknut  
(4 Pieces)

**52**

1/2\"-13 x 4 3/4\"  
Hex Bolt  
(2 Pieces)

**35**

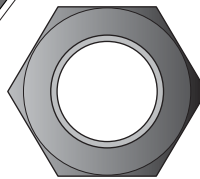

5/8\"-11  
Hex Nut  
(12 Pieces)

**36**

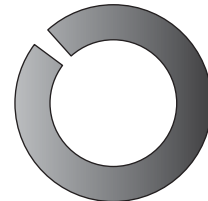

5/8\"  
Split Washer  
(4 Pieces)

**14**



**37**

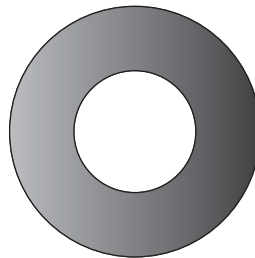

5/8\" Flat Washer (Thick)  
(8 Pieces)

**34**

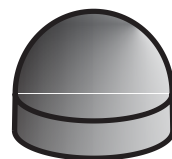

5/8\" Thread  
Protector  
(4 Pieces)

**14**



1\" OD x 6-3/16  
Pivot Tube (1 Piece)

# HARDWARE IDENTIFIER

**32**

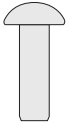

#8 x 1/2"  
Thread Forming Screw  
(4 Pieces)

**33**

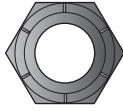

3/8"-16  
Nylon Locknut  
(4 Pieces)

**29**

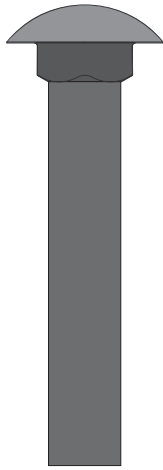

3/8"-16 X 2"  
Carriage Bolt  
(4 Pieces)

**26**

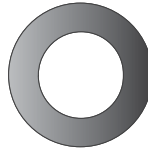

3/8" X 19mm Flat Washer  
(4 pieces)

**Hardware required for rim assembly**

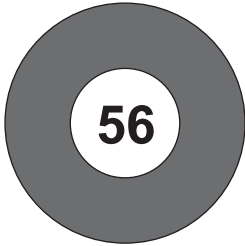

1/2" X 1-1/4" Dia.  
Peel & Stick Plastic-Washer  
(4 Pieces)

**7**

1/2"-13 x 11 1/2"  
Hex Bolt  
(2 Pieces)

**20**

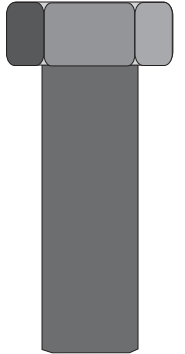

1/2"-13 X 1-1/2"  
Hex Bolt  
(2 Pieces)

**46**



3/8"-16 X 3-1/2"  
Hex Bolt  
(4 Pieces)

**26**

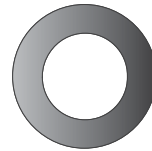

3/8" X 19mm Flat Washer  
(4 pieces)

**3**

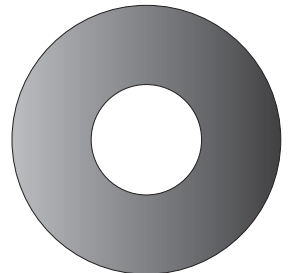

1/2" Flat Washer  
(16 Pieces)

**45**

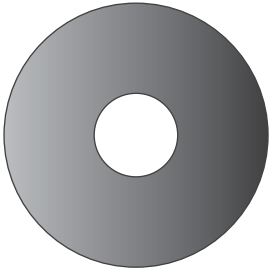

1 3/8"(OD) X 3/8"  
Flat Washer  
(4 Pieces)

**10**

1/2"-13 x 4 1/4"  
Hex Bolt  
(2 Pieces)

**5**

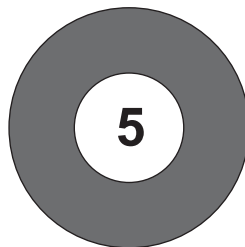

1/2" X 1-1/4" Dia. Plastic-Washer  
(18 Pieces)

**21**

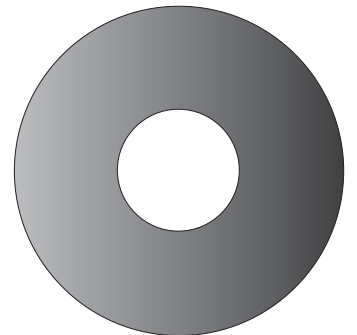

5/8" Flat Washer  
(2 Pieces)

**22**

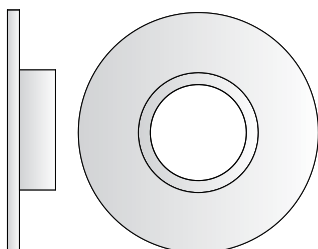

Step Bushing  
(4 pieces)

**53**

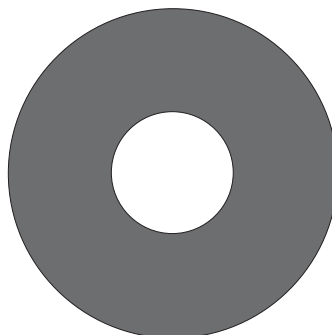

5/8" Plastic Washer  
(4 Pieces)

**51**



#10 X 1 1/8" Phillips  
Hex Head Self  
Tapping Screw  
(8 pieces)

# INSTALLATION TIMELINE

1. Prior to anchor system and goal assembly, call utility services for location of underground utility lines before you dig.
2. Vertical main post assembly is a two part process.

## PART 1

**Day 1.** Complete Anchor System Installation Instructions. (Below)

**Day 2-4.** Allow concrete to cure.

## PART 2

**Day 5.** Complete Goalrilla™ assembly instructions. (Requires four adults)

## ANCHOR SYSTEM INSTALLATION INSTRUCTIONS (Day 1)

### ⚡ WARNING

**Before digging hole for anchor system, check for buried power, gas, water, and telecommunication lines! Failure to do so could result in serious or fatal injury! Contact your local utility company if unsure.**

#### Items needed for Anchor Installation (not included)

- |  |                  |
|--|------------------|
| 11 - 80 lb. bags of concrete (2-3 extra recommended) | 1 - wheel barrow |
| 1 - post hole digger (optional)                      | 1 - garden hose  |
| 1 - 15/16" open end wrench                           | 1 - level        |
| 1 - 15/16" socket and ratchet (optional)             | 1 - tape measure |
| 1 - concrete form (see note after step 2)            |                  |

**Note: For best results with less vibration, anchor system should be independent of court. If pouring concrete for both at same time, add an expansion joint in between.**

**Note: When digging hole, if you hit rock and cannot dig through contact a contractor.**

1. Determine the location of the anchor system. The proper location is as **close to the court without making contact**, as shown in Figure 1. This, however, is a general rule. If you need to locate the anchor system in a location other than this, use the following dimensions as a guide.

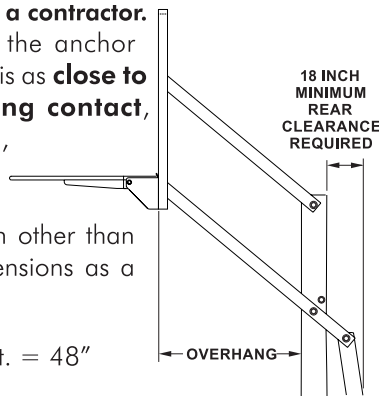

Overhang when adjusted to 10 ft. = 48"

2. Assemble anchor system as follows: Thread nut (#35) to bottom of threads on anchor bolt (#39) insert threads of anchor bolt (#39) through hole on anchor plate (#38) and secure with nut (#35). Repeat this step for the remaining anchor bolts. See Figure 2. Note: Each leg of anchor bolts should face the anchor bolt to the right. See Detail A.

**Detail A  
Bottom View**

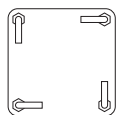

**THESE NUTS USED FOR LEVELING**

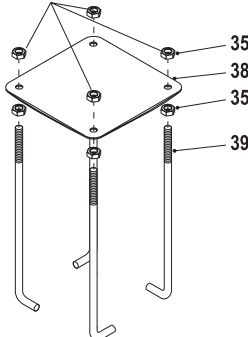

**Figure 2**

**Figure 1**

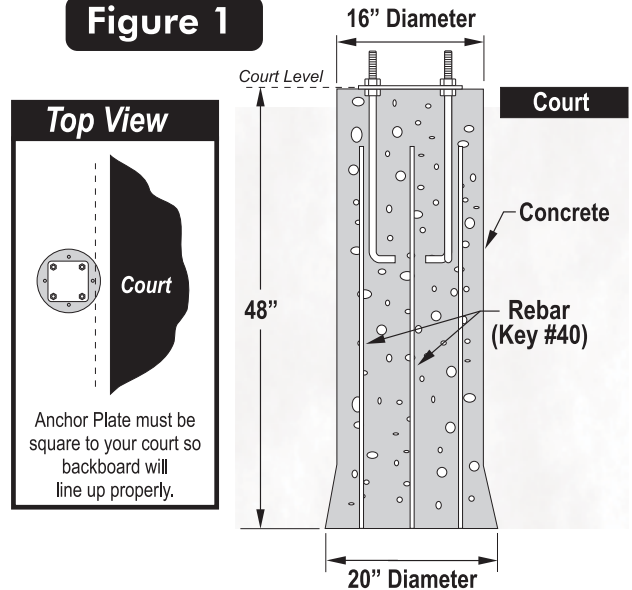

Anchor Plate must be square to your court so backboard will line up properly.

**Note: Using a concrete form for the top 4" of the concrete is recommended. Cardboard forms can be purchased at some hardware and home stores or a wooden form can be constructed out of 2 x 4's.**

**Note: Failure to dig and fill hole as instructed will result in increased system vibration.**

**\*Tip: It is always a good idea to purchase one or two extra bags of concrete, just in case you need them. If extra bags are not used you can return them to the store.**

3. Mix and pour concrete into hole. Follow instructions on concrete bag. Stop about 18" below court level.
4. Insert four reinforcement bars (Key #40) into concrete 8" apart creating a square in center on hole.
5. Place form in desired location and finish pouring concrete up to court level.
6. Push anchor system into concrete and agitate to work out voids in concrete. Immediately use a level to level and square anchor plate to playing surface. Clean off any concrete that may be on exposed threads.

**Note: The bottom four nuts will be forever embedded in concrete. The top four nuts remain on bolts and are used for leveling. (See Step 14 on page 10)**

Let concrete cure for a MINIMUM of 72 hours.

# GOALRILLA™ ASSEMBLY INSTRUCTIONS (Day 5)

## TOOLS REQUIRED FOR THE FOLLOWING STEPS

- |  |                              |
|--|------------------------------|
| 1 - 15/16" open end wrench               | 1 - Level                    |
| 1 - 15/16" socket and ratchet (optional) | 1 - Tape Measure             |
| 1 - 9/16" Deep Well Socket & Ratchet     | 1 - Rubber Mallet            |
| 1 - 3/4" Socket & Ratchet                | 1 - Set of Padded Saw Horses |
| 1 - 3/4" Open end Wrench                 | 1 - Ladder                   |
| 1 - 5-16" Socket Driver                  | 1 - Pair of Safety Glasses   |
| 1 - Cordless Drill & 9/64" Drill Bit     | 1 - Phillips Screwdriver     |

1. If not already pre-assembled, slide Plastic Actuator Sleeve (#15) over Steel Actuator (#16) and place Actuator Cap (#13) on top. Slide Pivot Tube (#14) in hole near the top of **Steel Actuator** and **Plastic Actuator Sleeve** until equal amounts stick out on both sides of Actuator. See Figure 3.

**Figure 3**

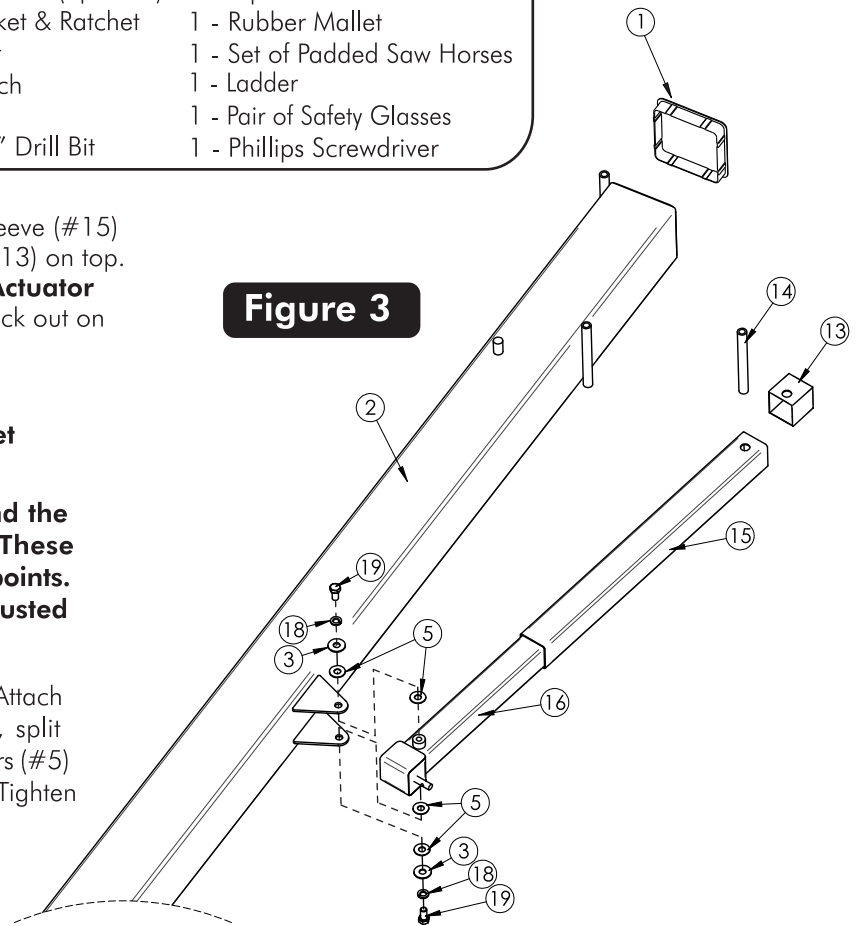

**NOTE: It may be necessary to use a rubber mallet to tap in Pivot Tube.**

**NOTE: It is important for the installer to understand the necessity of the Plastic washers (#5) provided. These washers adequately space painted parts at all pivot points. Neglecting the use of these washers will result in rusted parts.**

2. Lay Pole (#2) on its side on two padded saw horses. Attach Actuator (#16) to Pole (#2) using one bolt (#19), split lockwasher (#18), Washer (#3) and two plastic washers (#5) to thread into each side of Actuator. See Figure 3. Tighten bolts tight.
3. If Pole Cap (#1) is not already pre-installed insert it into the top of the Pole (#2).

**NOTE: Rounded caps go on the front part of the board arms.**

**NOTE: All board arms are made of rectangular tubing. Tightening hardware too tight may damage tubing and make adjustment of system difficult.**

4. Attach Lower Arm (#11) to Pole (#2), as shown in Figure 4, using a Bolt (#7), two Flatwashers (#3), four Plastic Washers (#5) and Lock Nut (#4). Do not tighten Bolt (#7) at this time.

**NOTE: Make sure "Goalrilla" lettering is right side up. DO NOT tighten bolt (#7) at this time.**

5. If Tube Plugs (#55) and (#50) are not already installed insert them into open ends of Lower Arm (#11). Rounded Tube Plugs (#50) go on the front end of Lower Arm (#11). It may be necessary to use a rubber mallet to tap plugs in.

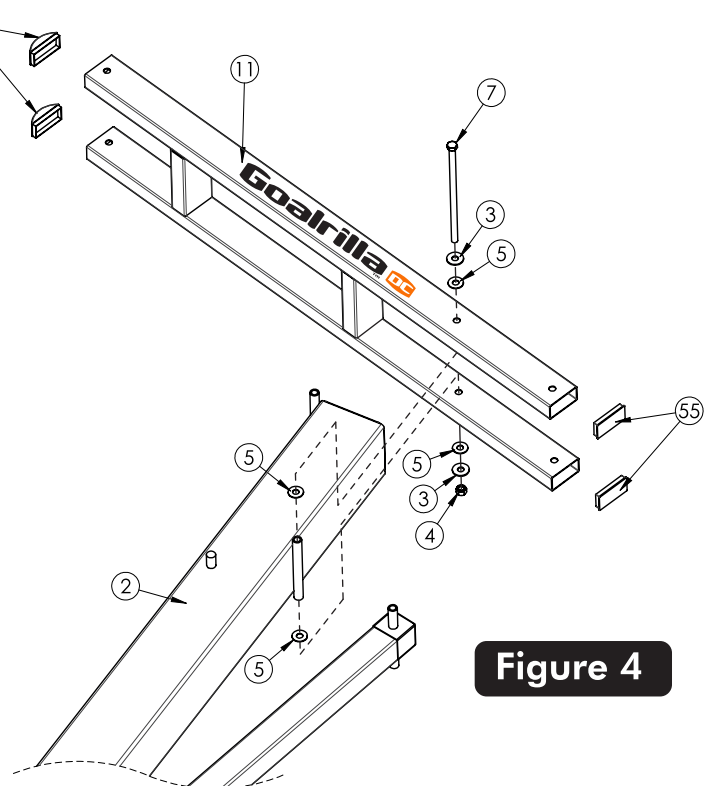
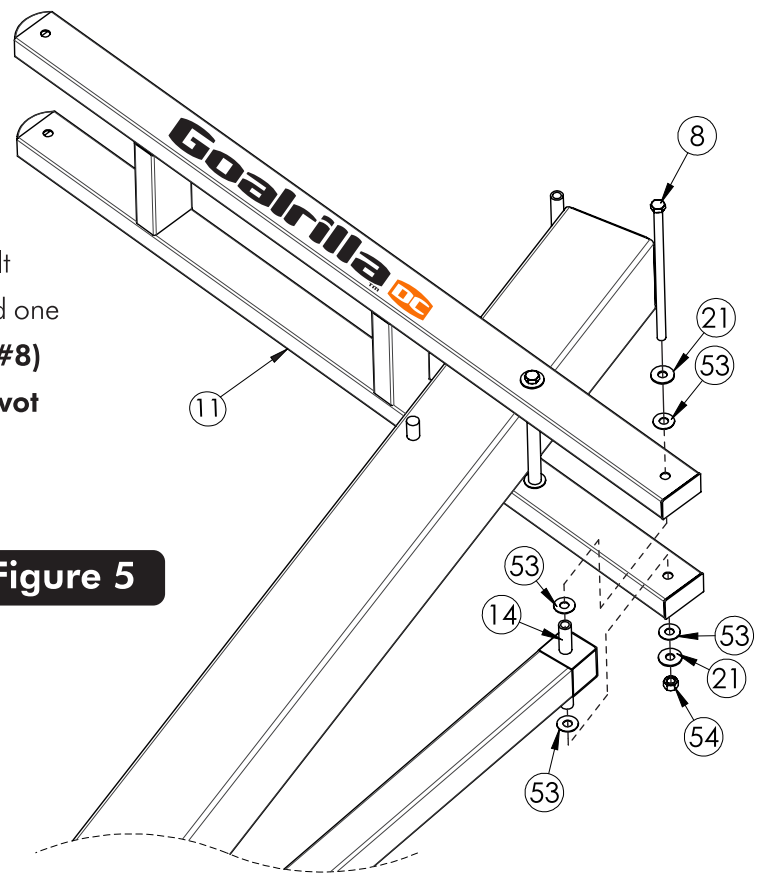

**Figure 4**



6. Secure Actuator (#16) to Lower Arm (#11) using one Bolt (#8), two flatwashers (#21), four Plastic Washers (#53) and one Lock Nut (#54). See Figure 5. **Tighten bolts (#7) and (#8) snug but, do not over tighten. Board Arms must pivot freely.**

**Figure 5**



7. Attach Middle Arm (#24) to Pole (#2), as shown in Figure 6, using Bolt (#7), two Flat Washers (#3), four Plastic Washers (#5) and Lock Nut (#4).

**NOTE: Tighten bolts snug but, do not over tighten. Board Arms must pivot freely.**

**Figure 6**

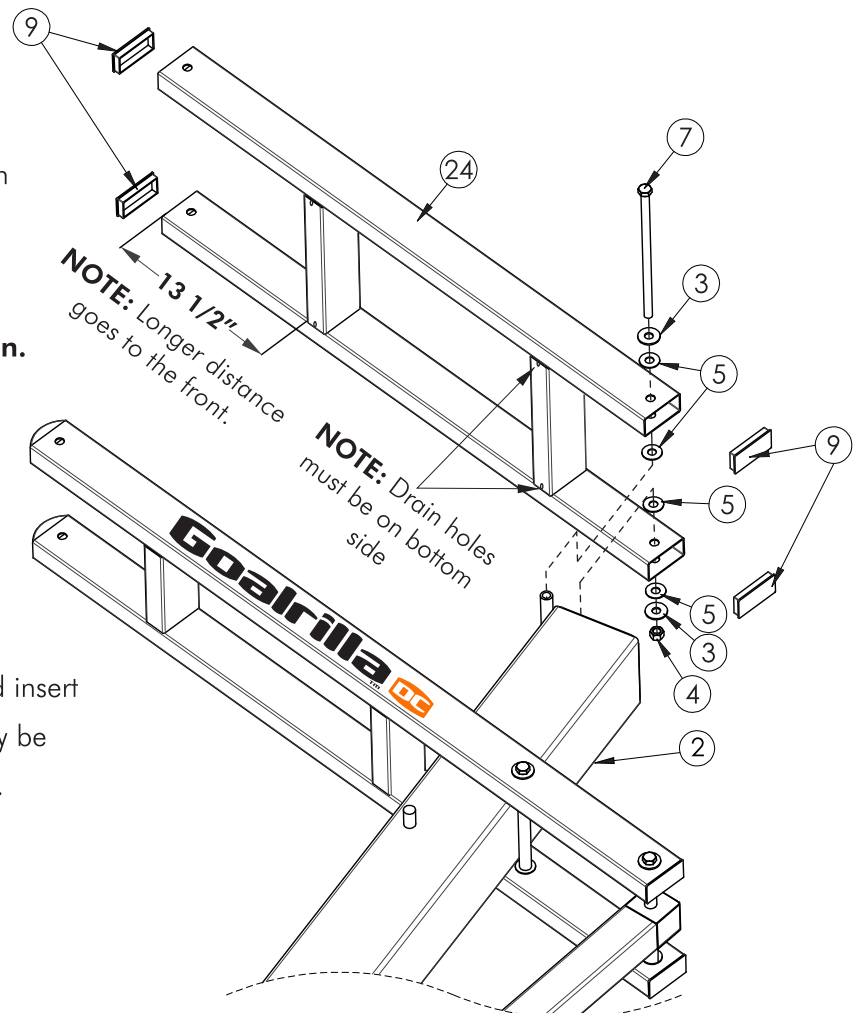

8. If the four Tube Plugs (#9) are not already installed insert them into open ends of Middle Arms (#24). It may be necessary to use a rubber mallet to tap the plug in.

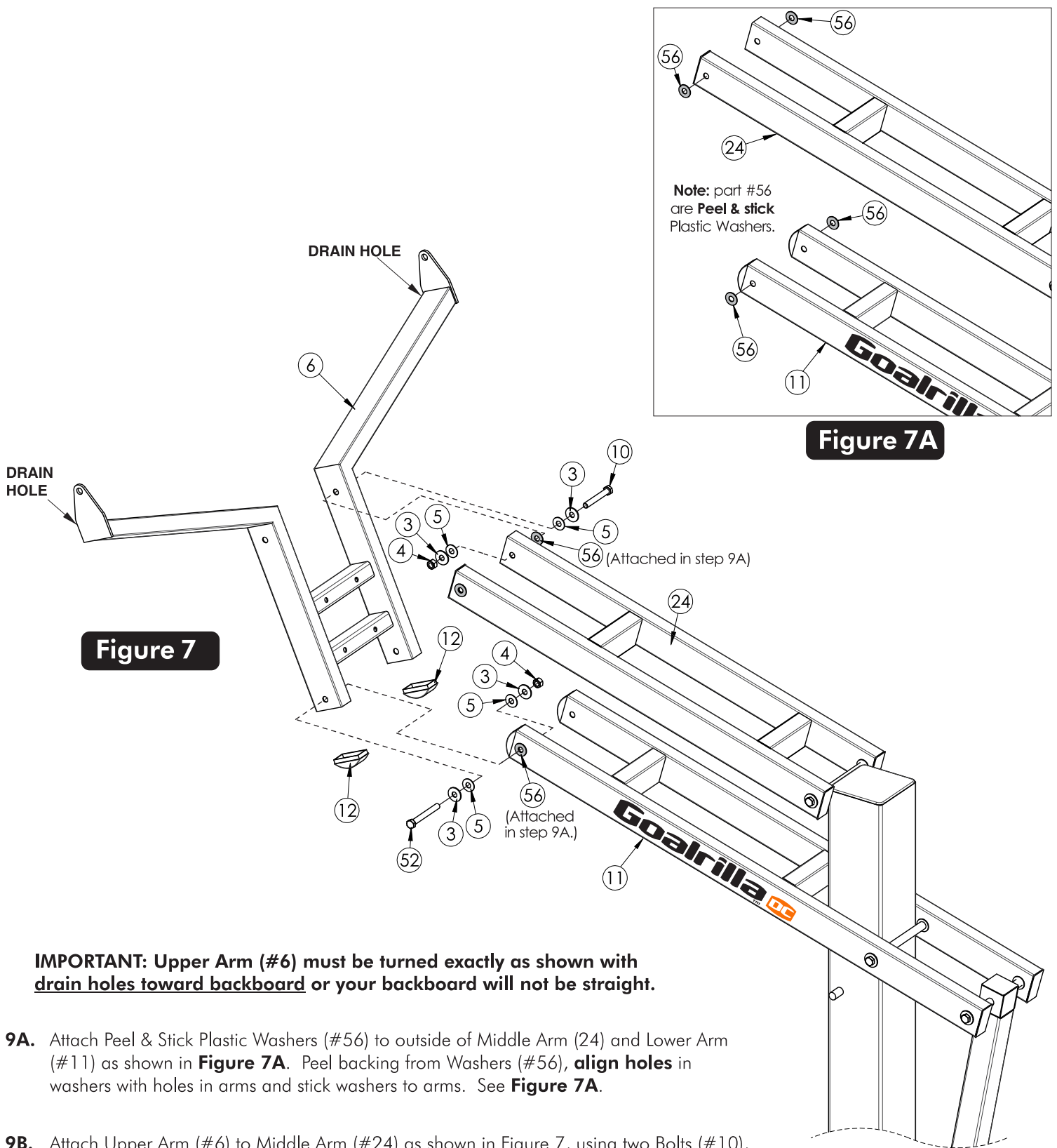

- 9A.** Attach Peel & Stick Plastic Washers (#56) to outside of Middle Arm (24) and Lower Arm (#11) as shown in **Figure 7A**. Peel backing from Washers (#56), **align holes** in washers with holes in arms and stick washers to arms. See **Figure 7A**.
- 9B.** Attach Upper Arm (#6) to Middle Arm (#24) as shown in Figure 7, using two Bolts (#10), four Flat Washers (#3), four Plastic Washers (#5) and two Lock Nuts (#4) in each arm.
- 10.** Attach Upper Arms (#6) to Lower Arm (#11) as shown in Figure 7, using Bolt (#52), two Flat Washers (#3), three Plastic Washers (#5) and Lock Nut (#4) in each side of Lower Arm (#11).
- 11.** If Tube Plugs (#12) are not already installed insert them into open ends of Upper Arm (#6). It may be necessary to use a rubber mallet to tap plugs in.



12. Attach Rim Beam (#25) to Upper Arm (#6), using four bolts (#46), four Flat Washers (#26), four Flat Washers (#45) and Lock Nut (#33) but do not tighten completely until instructed to do so in Step 20. **Make sure that angled end is attached to Upper Arm (#6).** See Figure 8 and Detail B.

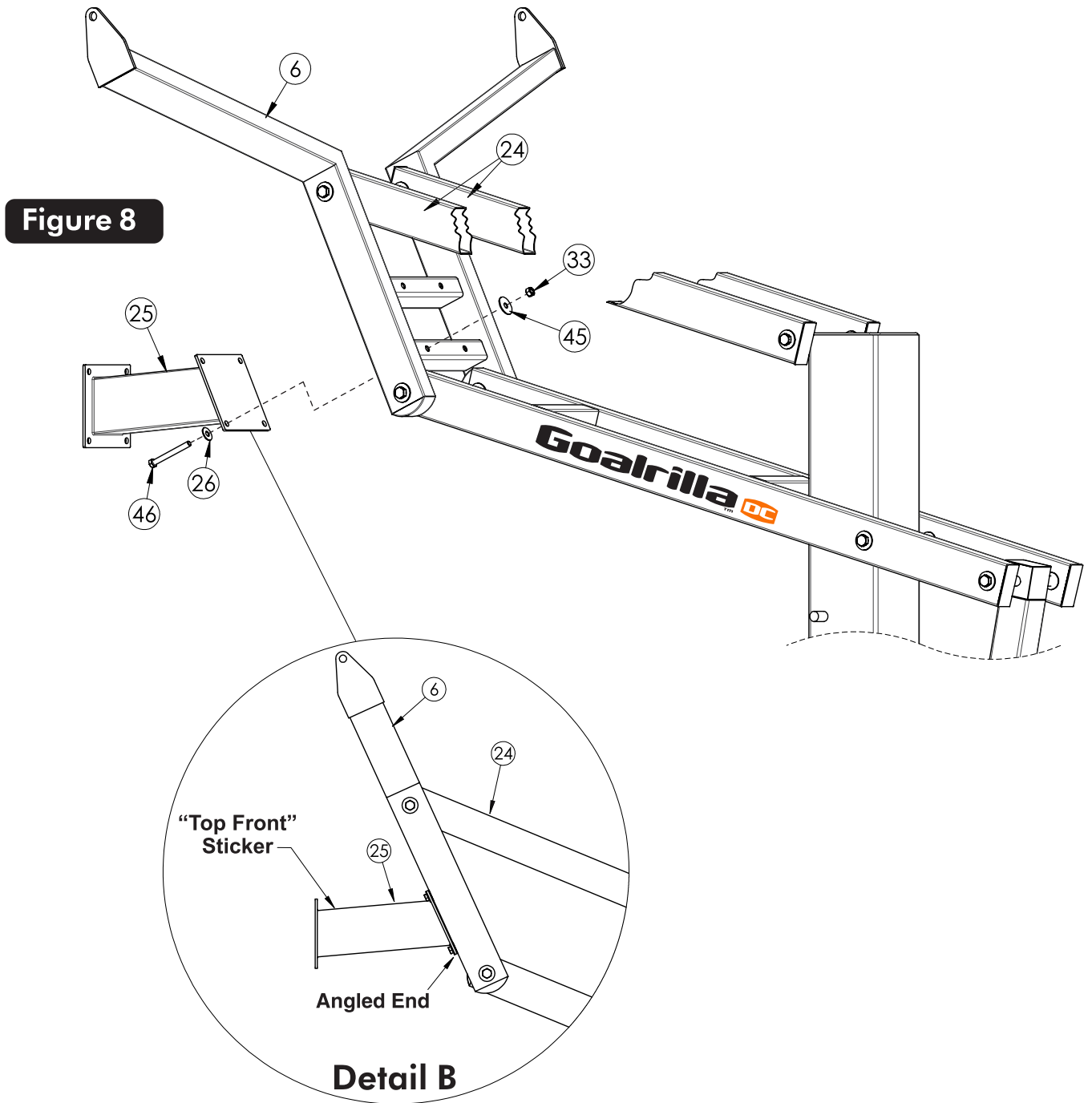

13. Locate hardware needed to mount pole to anchor bolts. You will need, eight flat washers (#37), four lock washers (#36), four hex nuts (#35) and four thread protectors (#34).

**NOTE: Do not remove the nuts #35 you installed in step 2 (pg. 5).**

**! CAUTION !**

**PLACING THE POST ON THE ANCHOR SYSTEM REQUIRES AT LEAST FOUR CAPABLE ADULTS. POLE WILL WANT TO LEAN WHILE ATTEMPTING TO STAND IT UP ON ANCHOR BOLTS.**

14. Put a flat washer (#37) on each anchor bolt. Lift post onto anchor system and secure with one flat washer (#37), one lock washer (#36) and one hex nut (#35) for each anchor bolt. Tighten Fasteners finger tight, leave loose enough to level pole. Place a level on pole and adjust bottom nuts #35 until pole is level (left to right and front to back). **Tighten top four hex nuts #35 tight.** See **Figure 9**.
15. Push on Thread Protector Cap (#34) until it is securely in place. Cap may be tight, push hard but **DO NOT** hit with a hammer! See **Figure 9** and **Detail A**.

Let concrete cure for a **MINIMUM** of **72** hours.

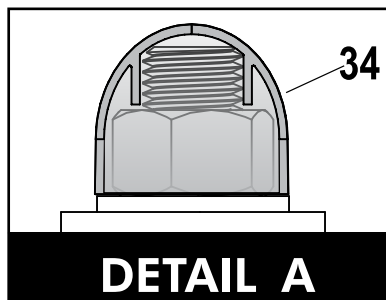
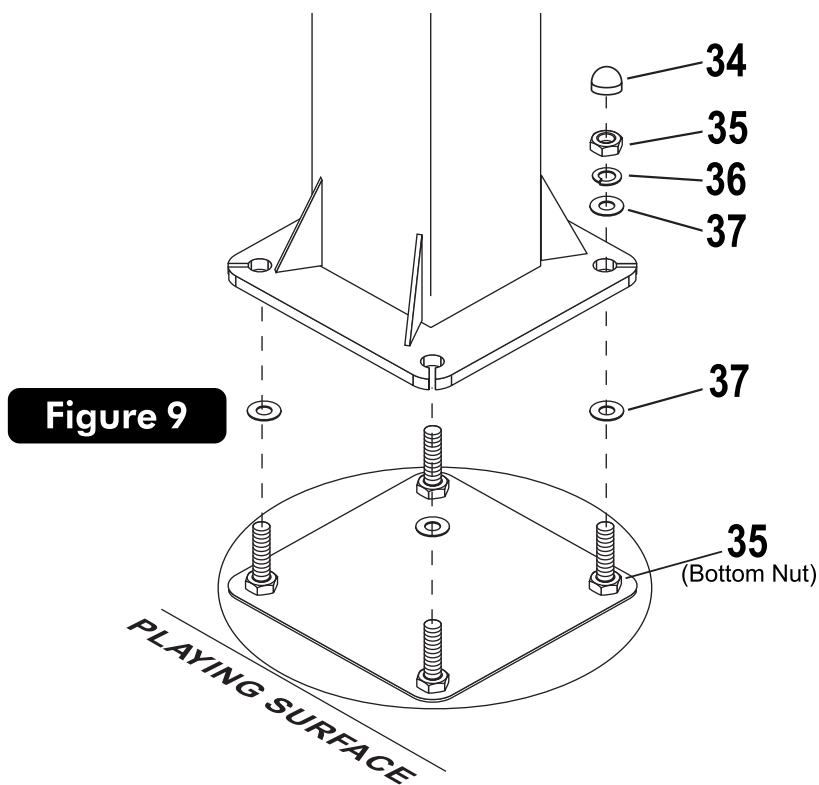

- NOTE:**  
If basketball system needs to be moved, **do not** try to salvage caps. Caps (#34) will be tight, please remove with pliers and discard. New caps will come in new anchor system.
- NOTE:**  
If (#34) caps are missing for any reason please call customer service.
- NOTE:**  
Bottom nuts #35 can be used for leveling system. See **Step 14**.

16. Slide Actuator Crank (#42) onto shaft on the bottom of Actuator (#16). Line up hole in shaft with hole in Actuator Crank and insert Pull Pin (#41) to secure. See Figure 10.
17. To aid in the assembly of the backboard lower the backboard, by turning the Actuator Crank, until the lower arm makes contact with the Safety Stop.

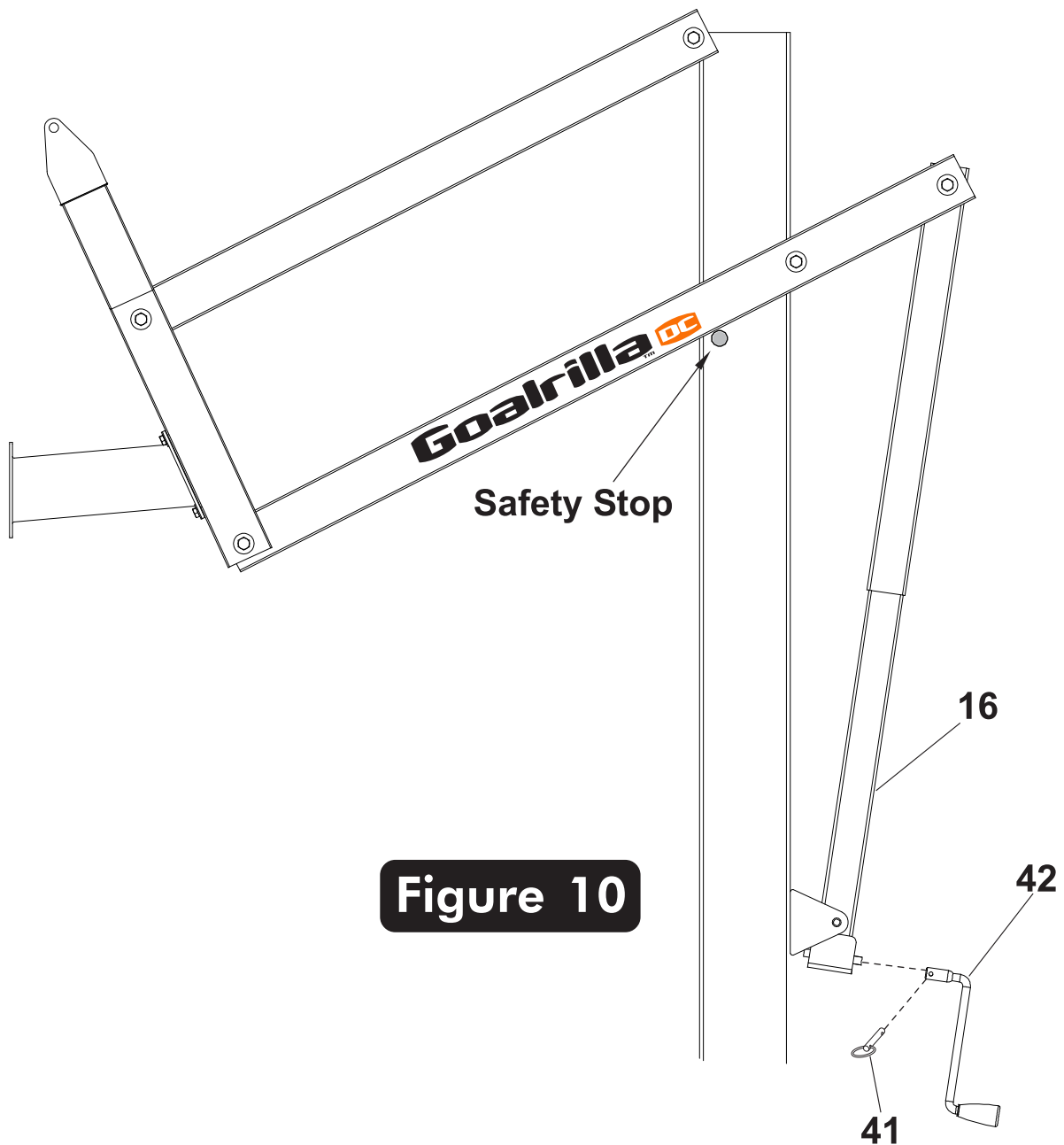

**Figure 10**

# CAUTION!

HANDLE BACKBOARD WITH CARE, IT IS A GLASS PRODUCT. ALWAYS WEAR SAFETY GLASSES AND GLOVES WHEN HANDLING GLASS.

# CAUTION!

ATTACHING BACKBOARD TO BOARD ARMS REQUIRES AT LEAST FIVE CAPABLE ADULTS.

**Note:** DO NOT over tighten these bolts. This is a pivot point. Snug is tight enough.

**Note:** Step Bushings (#22) have an adhesive back for ease of assembly, peel covering off bushing and stick bushing in hole.

- With at least four capable people, raise the backboard assembly up and have the fifth attach Upper Board Arm to the **inside** of the upper mounting bracket holes on backboard using one Bolt (#20), two step bushings (#22), (may be shipped already installed), one Plastic Washer (#5), two flat Washers (#3) and one thin locknut (#4) on each mounting bracket. See Figure 11.
- Mount Goal Assembly (#28) to Backboard bracket and Rim Beam (#25), using four carriage bolts (#29), four Washers (#26), and four locknuts (#33). **Tighten fasteners** but leave them **loose enough** to level Backboard and rim. See Figure 11.

- Place level across bottom frame of the backboard as shown in figure 11. If leveling is needed have a second person push up on one end of the backboard and adjust the backboard until level. While holding the backboard level, tighten hardware from Step 12.

- Place a level across rim assembly and adjust rim until it is level. Finish tightening the four nuts from **Step 19**.

If you want to see a video on how to level the backboard go to: <https://support.escaladesports.com/videos/>

# CAUTION!

NEVER USE RIM WITH COVERPLATE REMOVED!

- Attach Rim Cover Plate (#31) using four screws (#32). See Figure 11.
- Check all nuts and bolts to make sure everything is tightened properly. **DO NOT** over tighten pivot points, snug is tight enough.

**Note:** Be sure to install upper board arms to the **INSIDE** of backboard mounting brackets.

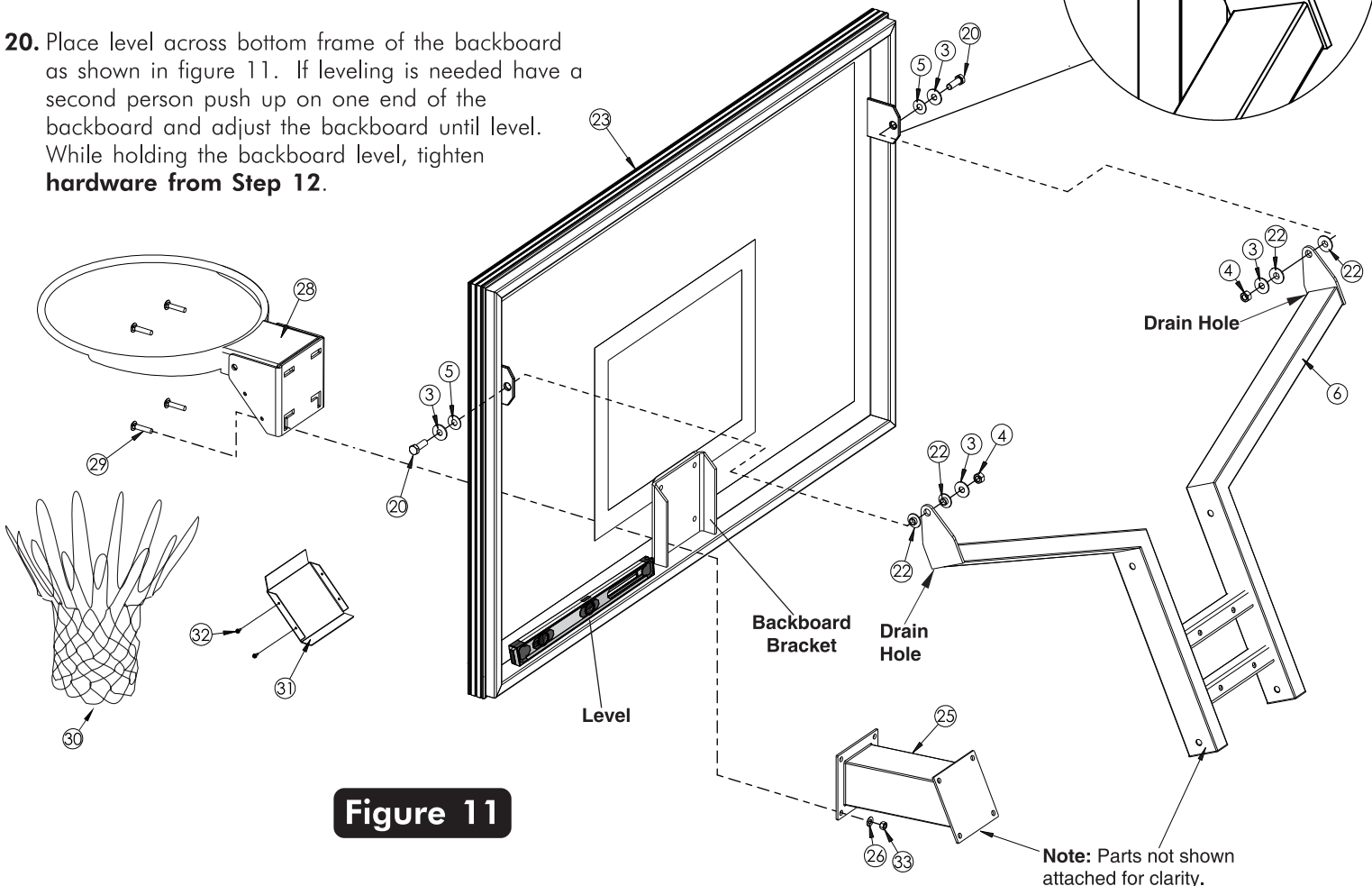
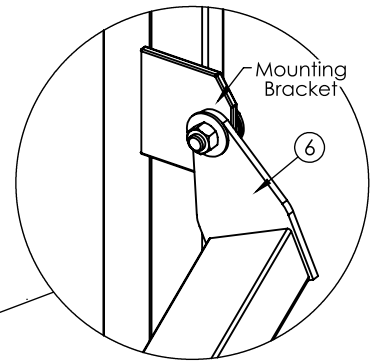

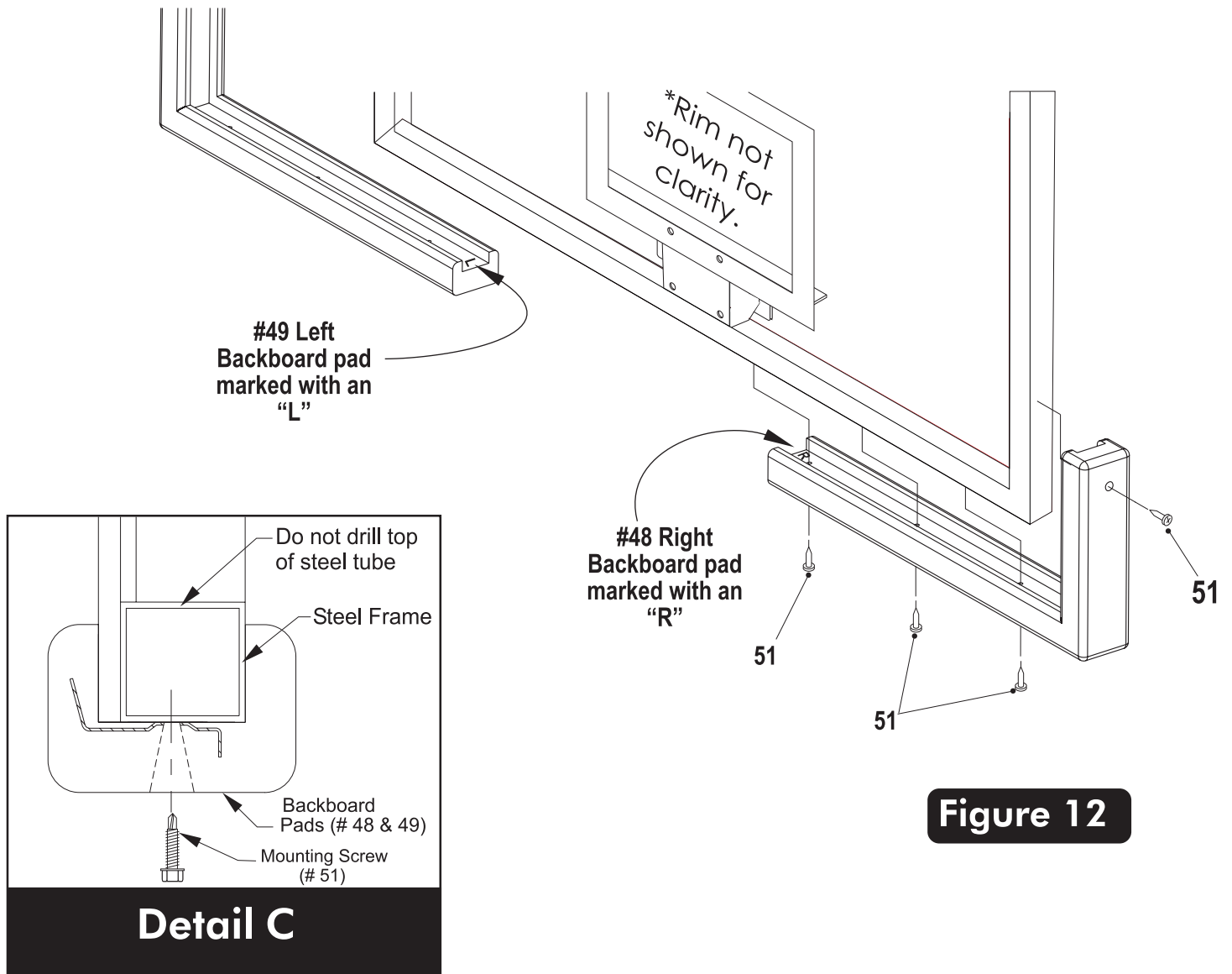

**Figure 12**

**Note: Part #48 is a Right Backboard pad & #49 is a Left Backboard pad.**

24. Use the Backboard Pads as a Template and mark the hole locations on the backboard frame.

**Note: Safety glasses required for Step 25.**

25. Drill 9/64 pilot holes through aluminum trim and into Steel backboard frame as shown in **Detail C**. **DO NOT** drill through both sides of tube.

**Note: Cordless drill recommended for screw installation. Do not over tighten screws causing screws to strip.**

**Note: To install screws, it will be easier if you use a cordless drill with 5/16" socket (instead of Phillips head.)**

26. Secure Backboard pads using screws provided (#51) as shown in **Figure 12**.

**Two adults are recommended for this step, one to level and one to adjust the bottom #35 nuts.**

27. If further leveling is required loosen top #35 nuts but do not loosen past the top of #39 "J" Bolt. **DO NOT REMOVE NUTS #35.** Place a level on pole and adjust bottom nuts #35 with a 15/16" open end wrench until pole is level. Tighten top #35 hex nuts. See **Detail D**.

28. Secure Post Pad (#44) to front of pole by wrapping straps around the back pole and sticking to velcro on opposite side of pad. Top Post Pad straps should be above post ears. See **Figure 13**.

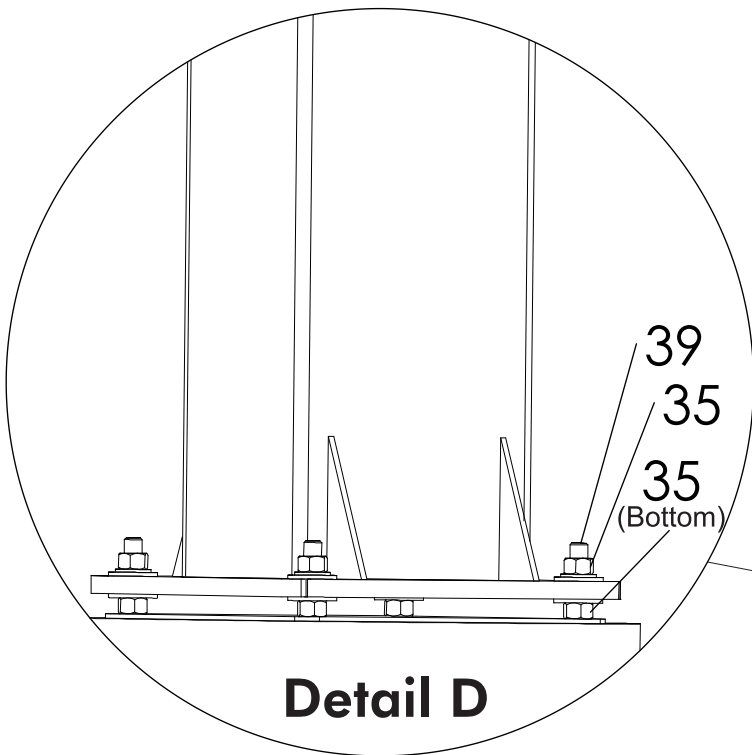
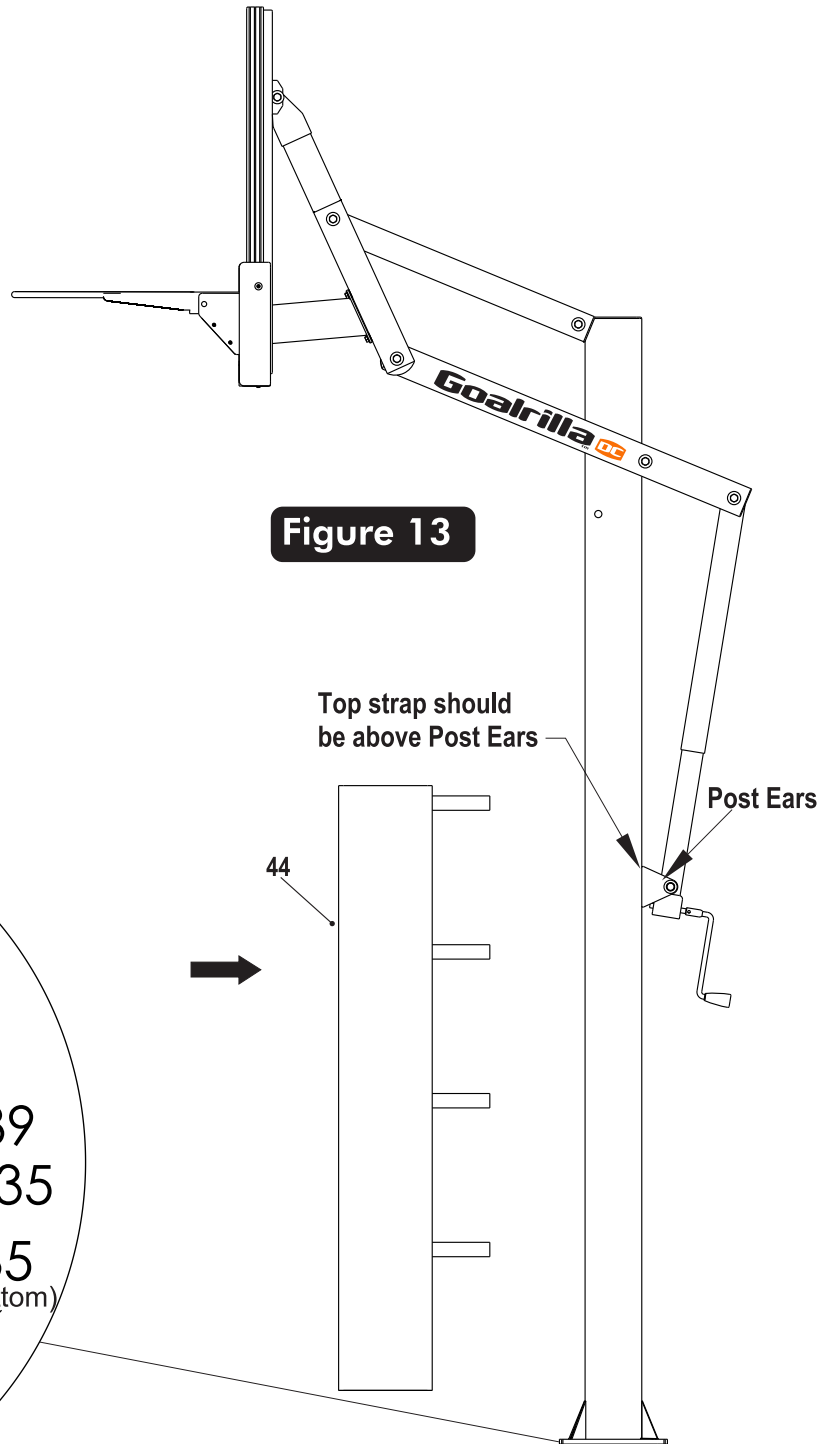



29. Raise Backboard to 10 FT. regulation playing height. Measure from top of rim straight down to the playing surface.

30. Using tape - mark the **side** of the steel actuator (#16) just under the plastic actuator sleeve (#15) at this 10 ft rim height. See **Figure 14**.

31. Lower backboard all the way down. Do not force actuator once backboard is in it's lowest position. See **Figure 15**.

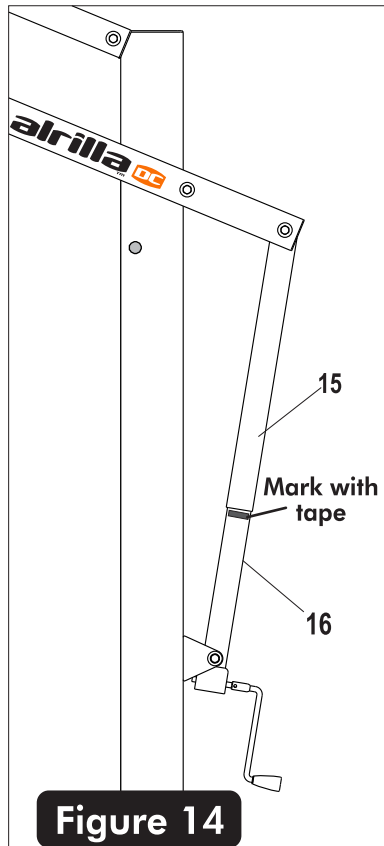

**Figure 14**

Set at 10 feet

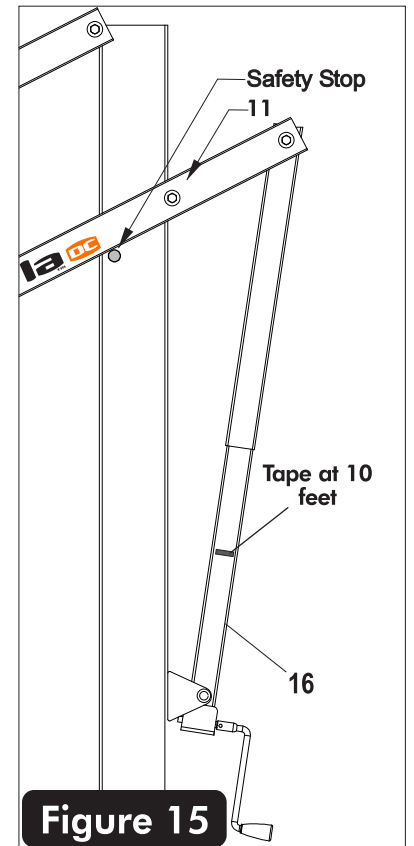

**Figure 15**

Lowered all the way down

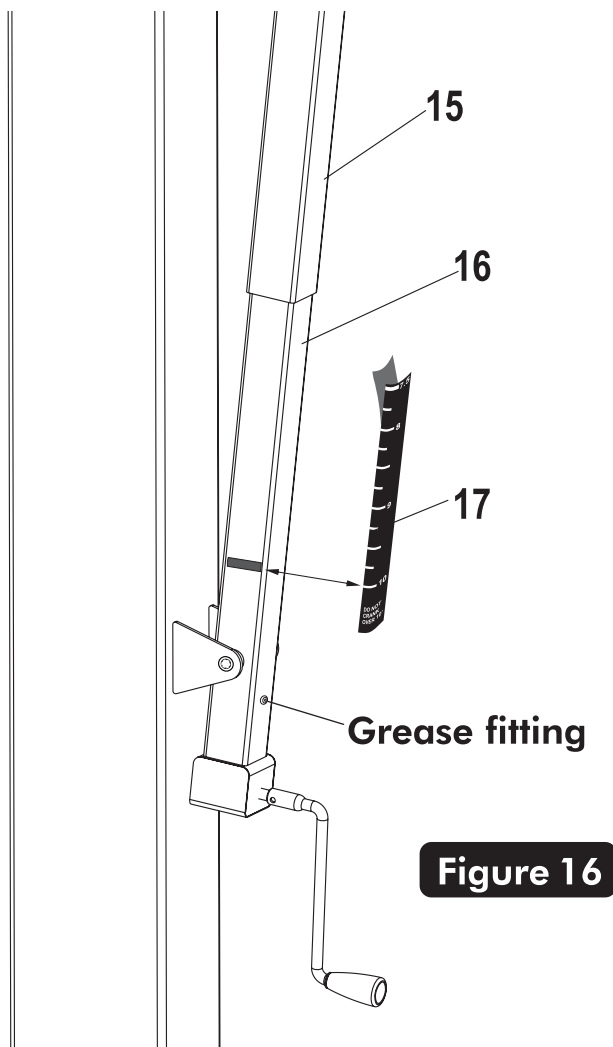

**Figure 16**

32. **Do not** remove adhesive backing from height decal (#17) yet. Carefully place height decal on backside of steel actuator (#16) and line up the 10 ft mark on the tape with the 10 ft mark on the height decal. Decal should fit correctly onto the backside of the steel actuator. ( If not , simply trim to fit the top of the actuator decal).

33. Remove the adhesive backing from the Height Decal (#17). Next, carefully align and stick decal to backside of steel actuator (#16) starting at the **10 ft mark first**. Be sure to keep the height decal straight and rub out all air bubbles. See **Figure 16**.

## LIMITED LIFETIME WARRANTY

---

This consumer warranty extends to the original consumer purchase of any MICCA Group Product (hereinafter referred to as the "Product").

**WARRANTY COVERAGE:** MICCA Group warrants to the original Consumer Purchaser that any Product of its manufacture is free from defects in material and workmanship. THIS WARRANTY IS VOID IF THE PRODUCT HAS BEEN DAMAGED BY ACCIDENT, UNREASONABLE USE, NEGLIGENCE, IMPROPER SERVICE, FAILURE TO FOLLOW INSTRUCTIONS PROVIDED WITH THE PRODUCT OR OTHER CAUSES NOT ARISING OUT OF DEFECTS IN MATERIAL OR WORKMANSHIP.

Subject to proper installation and normal Residential use, MICCA Group warrants, subject to the limitations below, to the original retail purchaser all structural components of the Goalrilla™ System to be free of defects in material and workmanship for the duration of ownership by the original retail purchaser.

Merchandise must be shipped prepaid with a copy of proof of purchase to MICCA Group factory for examination to determine if the basketball system needs to be repaired or replaced. Any labor costs, travel expenses and any other changes involved in the removal, installation or replacement of the defective/repairs parts from/to your Goalrilla™ System will be the purchaser's responsibility. Shipping charges for replaced or warranted merchandise sent back to the customer from MICCA Group factory must be prepaid by the customer in advance. If not, the replacement shipment will be sent out collect.

MICCA Group reserves the right to examine photographs or physical evidence of merchandise claimed to be defective, and to recover said merchandise, prior to authorization of warranty claims. A "Returned Goods Authorization" number may be required, please call for details prior to the return of any photographs or merchandise.

This limited lifetime warranty is expressly in lieu of all warranties, expressed or implied, including warranties of merchantability or fitness for use. MICCA Group does not assume or authorize any person or representative to assume for us, any other liability in connection with the sale of our products.

The remedy of repair or replacement stated above is MICCA Group exclusive remedy. MICCA Group will not be liable for any other damages or expenses which may incur, including but not limited to incidental or consequential damages. MICCA Group assumes no other obligations or liability on the part of the purchaser, and MICCA Group neither assumes nor authorizes any other person to assume for it any other liability in connection with the goods sold.

This warranty shall not apply in any manner to parts or accessories not manufactured by MICCA Group.

### NOT COVERED BY THIS WARRANTY

- Any merchandise subjected to Non-residential abuse, negligence, improper installation, vandalism, acts of God, alteration of product, or any other events beyond the control of MICCA Group.
- Paint or rusted parts. Paint kits will be available to assist in normal maintenance.
- Hanging on the rim will void your warranty: Rims are not warranted for any defects other than workmanship. Torn back plates, damaged springs, bent rings, damaged eyebolts, and torn or distorted rim supports result from hanging on the rim and are not warranted.
- Shipping charges both ways. Note: Any merchandise shipped to MICCA Group collect will be refused.
- Dealer service charges, labor charges and travel expenses associated with replacement of repair of warranty item.

**WARRANTY DISCLAIMERS:** ANY IMPLIED WARRANTIES ARISING OUT OF THIS SALE, INCLUDING BUT NOT LIMITED TO THE IMPLIED WARRANTIES OF MERCHANTABILITY AND FITNESS FOR A PARTICULAR PURPOSE, ARE LIMITED IN DURATION. MICCA GROUP SHALL NOT BE LIABLE FOR LOSS OF USE OF THE PRODUCT OR OTHER CONSEQUENTIAL OR INCIDENTAL COSTS, EXPENSES OR DAMAGES INCURRED BY THE CONSUMER OF ANY OTHER USE.

Some states do not allow the exclusion or limitation of implied warranties or consequential or incidental damages, so the above limitations or exclusions may not apply to you.

LEGAL REMEDIES: This warranty gives you specific legal rights, and you may also have other rights which may vary from state to state.

### WARRANTY GUIDELINES IS REQUIRED FOR ALL WARRANTY CLAIMS

1. Proof of Purchase (original retail purchaser) is required for all warranty claims.
2. Call or write MICCA Group to receive a Return Authorization # and determine specific needs.

Phone: 1800-551-443

Or E-mail us at: [information@goalrilla.com.au](mailto:information@goalrilla.com.au)

# CARE AND MAINTENANCE

## BACKBOARD CARE AND MAINTENANCE

### Items needed to clean backboard:

- 100% cotton soft cloth, (only)
- Glass cleaner

Clean backboard using only a **100% Cotton** soft cloth and glass cleaner Clean glass as you would clean household windows. Strong cleansers will damage backboard and void warranty

## RIM

**Only hang from the rim briefly to regain balance or avoid injuring others. Release the rim as soon as safely possible.** Rims are not warranted for any defects other than workmanship. Torn back plates, damaged springs, bent rings, damaged eye bolts and torn or distorted rim supports result from hanging on the rim and are not warranted.

The goal should not be cranked over 10'. Adjustments of the goal should be done under adult supervision.

When attempting slam dunk activity you should always wear a mouth guard to avoid dental injury.

## MAINTENANCE

To ensure ease of operation, lubricate all pivot points at least every 6 months or as needed with a good lubricant such as WD-40.

## RUST

Inspect your pole periodically, if rust should appear, remove loose paint, sand lightly, primer and paint with exterior flat matte finish enamel paint.

# B6101 PARTS LIST

Key#	Part #	Description	Qty	Key#	Part #	Description	Qty
1	3M-8947-00	6" X 8" Tube Plug	1	29	1B-7025-10	3/8-16 X 2 Carriage Bolt	4
2	1A-7685-02	Post Assembly 6" X 8"	1	30	3F-6010-00	Net	1
3	2B-6093-10	1/2 Flat Washer	18	31	2S-6421-00	Rim Cover Plate	1
4	2B-6242-10	1/2-13 Nylon Locknut (thin)	8	32	1B-6238-01	#8 X 1/2 Self Tapping Screw	4
5	3M-6245-01	1 1/4 Dia. Plastic Washer	22	33	2B-6238-10	3/8-16 Nyloc Locknut	8
6	1A-7681-00	Upper Board Arm	1	34	3M-9040-01	5/8 Thread Protector	4
7	1B-7026-10	1/2-13 X 11 1/2 Hex Bolt	2	35	2B-6097-10	5/8-11 Hex Nut	12
8	1B-6989-10	5/8-11 X 11 1/2 Hex Bolt	1	36	2B-6099-10	5/8 Split Lock Washer	4
9	3M-6834-00	1 9/16 X 3 5/32 Tube Plug	4	37	2B-6034-10	5/8 Flat Washer (thick)	8
10	1B-6993-10	1/2-13 X 4 1/4 Hex Bolt	2	38	2S-6494-01	Anchor Plate	1
11	1A-7682-01	Lower Board Arm	1	39	2B-6096-03	5/8-11 X 18 "J" Bolt	4
12	3M-8936-00	Radius Tube Plug 40 X 80 mm	2	40	1S-6152-00	#3 X 40 Rebar	4
13	3M-6892-00	Actuator Cap	1	41	7B-6255-00	Pull Pin	1
14	8S-6895-00	Pivot Tube	1	42	4A-8257-00	Actuator Handle	1
15	2M-6524-00	Actuator Sleeve	1	43	2L-7252-07	This Manual	1
16	4A-7810-00	Actuator Square	1	44	3M-6895-00	Post Pad	1
17	4L-8143-00	Height Decal DC72E1	1	45	2B-6237-10	3/8 X 1 3/8" OD Flat Washer	4
18	2B-6094-10	1/2 Split Lock Washer	2	46	1B-7024-10	3/8-16 X 3 1/2 Hex Bolt	4
19	1B-6215-10	1/2-13 x 1 Hex Bolt	2	47	NOT USED		
20	1B-6486-12	1/2-13 x 1 1/2" Hex Bolt	2	48	3M-6894-00	Backboard Pad Right	1
21	2B-6098-10	5/8 Flat Washer (thin)	2	49	3M-6894-01	Backboard Pad Left	1
22	7B-6391-00	Step Bushing	4	50	3M-8948-00	Radius Tube Plug 50 X 100 mm	2
23	6A-7528-00	Backboard Assembly - 42" x 72"	1	51	1B-6999-00	#10 X 1 1/8" Phil. Hex Head Screw	8
24	1A-7683-01	Middle Board Arm	1	52	1B-7022-10	1/2"-13 X 4 3/4 Hex Bolt	2
25	1A-7684-01	Rim Beam	1	53	3M-8931-00	5/8 Flat Plastic Washer	4
26	2B-6289-10	3/8 X 19mm Flat Washer	8	54	2B-6304-10	5/8-11 Nylon Lock Nut (thin)	1
27	3M-6833-00	Goal Spacer Plate (Pre-Installed)	1	55	3M-6464-00	2 X 4 Tube Plug	2
28	6A-6328-02	Goal Assembly	1	56	3M-8950-00	5/8 Plastic Washer (peel & stick)	4

